

# POWER SOAK™ INSTRUCTIONS & INFORMATION

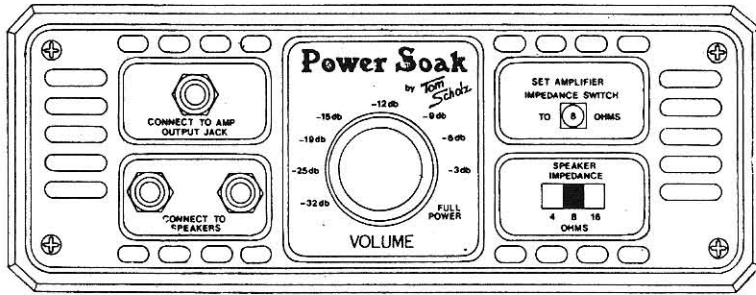

- Compatible with both tube and solid state amps. accepts 4, 8, 16 ohm speakers.
- Also designed for headphone/direct line use.
- Input impedance is correctly maintained for any volume selected.
- Provides automatic speaker protection for single 16 ohm cabinet used with 100 watt heads regardless of volume settings.

The Power Soak™ has been designed for use with all these amps:

Tube amps 110 watts RMS output or less at 4, 8 or 16 ohms.  
 Solid State amps of 120 watt RMS output or less into 4 ohms.  
*Note:* Solid State Amps requiring an 8 ohm speaker must use external adaptor (*See reverse*)  
**Any Amp exceeding the above output limits may be used by connecting it to two or more Power Soaks™. Contact Scholz R & D for specific instructions.**

- step 1 Place Power Soak™ in a horizontal position away from amp cooling vents (ex: On Marshall heads place Power Soak™ on far right hand side). Do not enclose or cover.
- step 2 **TUBE AMPS:**  
 Find speaker cabinet impedance (see chart on reverse). Set Power Soak™ speaker impedance selector" to that number.
- SOLID STATE AMPS:**  
 Set Power Soak™ "Speaker Impedance Selector" at 8 ohms for **ALL SOLID STATE AMPS AT ALL TIMES. USE EXTERNAL ADAPTOR WHEN REQUIRED.** (*See diagram and amp listings on reverse side.*)
- step 3 If amplifier model is equipped w/speaker impedance switch set it to number displayed in window above "Speaker Impedance Selector" on Power Soak™.
- If amplifier doesn't have impedance selector switch, disregard this step. Impedance is automatically set.
- step 4 Plug 1/4" phone cable from speaker cabinet to either "Connect to Speakers" jack on Power Soak™. Two cabinets may be connected.
- step 5 Plug 1/4" phone cable between speaker output on rear panel of amplifier and "Connect to Amplifier Output Jack" on Power Soak™.
- Note: The speaker common of many amplifier outputs are not grounded. All speaker cables should therefore have plastic ends or be insulated with tape whether or not a Power Soak™ is being used. Shielded cables are recommended for lengths longer than 6'*
- step 6 Set amplifier and Power Soak™ to desired levels.

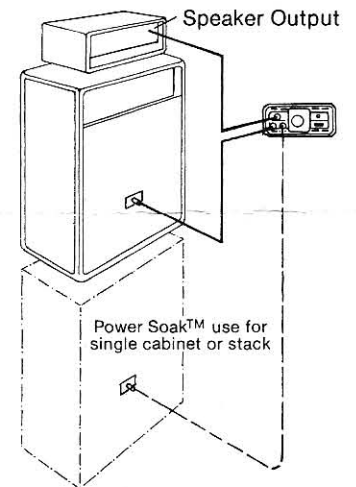
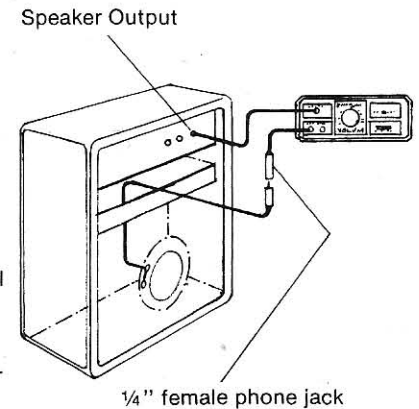

## TIPS FOR POWER SOAK™ USAGE

- Set all master volumes (if applicable) at full settings to allow output stage of amplifier to be overdriven. Set Power Soak™ at a low volume. Adjust amplifier volume for desired distortion. Adjust Power Soak™ for desired volume.
- If sound gets "muddy" - decrease bass settings while increasing treble and presence settings.
- To help control unwanted feedback
  - 1 - Reduce Power Soak™ volume
  - 2 - If loud sound levels are necessary, reduce amplifier volume (gain). (ex-High end feedback, reduce treble setting. Low end feedback, reduce bass settings.)
- To increase sustain at low sound levels increase amp volume (gain) or add a pre-amp while keeping Power Soak™ at low settings. Decrease bass settings and boost treble and mid-range.

**FOR HEADPHONES:** Use a standard headphone adaptor (1/4" female stereo to 1/4" male mono.) Plug into either "Connect to Speakers" jack and set Power Soak™ at -32db (PHONES) position.

**TUBE AMP:** When using amplifier with speaker impedance switch - set amplifier and Power Soak™ impedance switches to 8 ohms. Amplifiers designed for only 8 ohm cabinets - set Power Soak™ selector at 8 ohms. Amplifiers designed for only 4 ohm cabinets - set Power Soak™ selector at 4 ohms.

**SOLID STATE:** Set Power Soak™ selector at 8 ohms, use external resistor when applicable.

**LINE OUT: WHEN USING A DIRECT LINE WITH A SPEAKER** - Set Power Soak™ and amplifier impedance switches normally. Connect direct line to Power Soak™ speaker jack. Maximum Power Soak™ volume settings from -32db to -12 db may be used. (7 volts maximum line signal).  
**LINE OUT: WHEN USING A DIRECT LINE WITHOUT A SPEAKER** - use the same impedance selecting procedure required for headphone use (above). Connect direct line to unused Power Soak™ speaker jack. Power Soak™ volume settings from -32db to -12 db may be used.

*NOTE: If amplifier is being "direct connected" to a device/mixing console without transformer balanced inputs, a standard "line balancing" transformer should be used.*

## FOR TUBE AMPLIFIERS

Some common speaker cabinet impedances  
(Set Power Soak™ "speaker impedance selector"  
to this number)

<i>Make &amp; Model</i>	<i>Total Impedance (ohms)</i>
Marshall, Hi-Watt, Sound City, Orange, 4x12" speaker cabinet	
1 cabinet	16
2 cabinets	8
Music Man 210, 212,	4
Ampeg VT-22	8
Music Man 112, 115	8
Fender Twin,*Pro, Dual Showman Bandmaster and Bassman (separate cabinet style)	*excluding 135 watt or greater models 4
When using an extension speaker with main speaker	(use 4)
Ampeg V-4, 4x12" speaker cabinet,	
Music Man 412GH 4x12" speaker cabinet	
1 cabinet	8
2 cabinets	4

Note: Use "Low" setting on all Music Man 130 and 150 watt models.

If not listed, obtain impedance from manufacturer.

## FOR SOLID STATE AMPLIFIERS

Some amps that can be used without external adaptor:

Acoustic 124, 125, 117, 230, 126, 220, 118

Lab Series L-3

Yamaha G-100 series

Randall RG120, RB120,  
RG60, RSS140

Kustom - all III Series

Sunn Beta Series

Traynor TS-15, TS-75, TS-100,  
TS-140

Set Power Soak™  
"Speaker Impedance  
Selector" to  
**8** ohms  
regardless  
of speaker  
cabinet  
impedance.

Use only speakers with correct impedance for your amp

Some amps which require an external adaptor

Lab Series L-5, L-7, L-9

Yamaha G-50

Traynor T-5-25, T5-50

Pignose 30/60, Crossmix

Legend - GC-112, GC-212

50 Series

Set Power Soak™  
"Speaker Impedance  
Selector" to  
**8** ohms  
use external  
adaptor  
(see below)

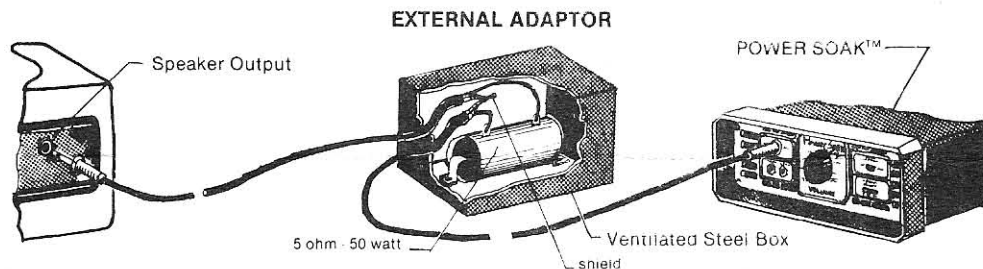

Solid state amps of 120W RMS or less that are NOT rated for 4 ohms or 2 ohms may be used by wiring a 5 ohm, 50W resistor in series between the amplifier output and the Power Soak™ as shown above.

## SOLID STATE RESISTOR MODIFICATION OFFER

The 5 ohm resistor described above may be built into your Power Soak™ complete with an "in-out" switch for additional cost of \$20. Send Power Soak™ to Scholz Research & Development. We will modify your unit and return it within one week.

## SPECIFICATIONS:

MAXIMUM CONTINUOUS POWER DISSIPATION: 110 watts RMS

INPUT IMPEDANCE: with 8 ohm impedance speaker: 7.8 to 10.2 ohms

with 4 ohm impedance speaker: 4.1 to 5.6 ohms

INSERTION LOSS AT FULL POWER SETTING: NONE

At "Full Power" setting the Power Soak™ is switched out of the circuit except when using a single 4-12" 16 ohm speaker cabinet. The maximum power provided is reduced by 2.5 db to protect the speakers from being blown.

BATTERIES: NONE.

AC POWER REQUIRED: NONE

DIMENSIONS: 10.3" x 9.3" x 3.5"

WEIGHT: 4 lbs.

WARRANTY: 2 years parts/labor

ADDED TECHNICAL INFORMATION:

For all volume settings below -15db: Input impedance to Power Soak™ is approximately the impedance shown in window regardless of speakers or headphones plugged into it.

ELIMINATING HIGH GAIN ELECTRONIC LOOP -

In some rare cases a high squeal may be caused by excessive high end gain when guitar is near Power Soak™ (not to be confused with high end acoustic feedback). Connect a grounding wire from rear panel screw to amplifier chassis.

NOTE: "Connect to Speaker" jacks are wired in parallel.

AUDIO ATTENUATION: (Approximate)

Step 1	0 db	Full Power
Step 2	3 db	
Step 3	6 db	
Step 4	9 db	
Step 5	12 db	
Step 6	15 db	
Step 7	19 db	
Step 8	25 db	
Step 9	32 db	Phones

Power Soak™ is the first in a series of products for the professional guitarist by  
**Scholz Research & Development**  
PO Box 191  
Lincoln Center  
MA 01773